

02

FOR APPROVAL

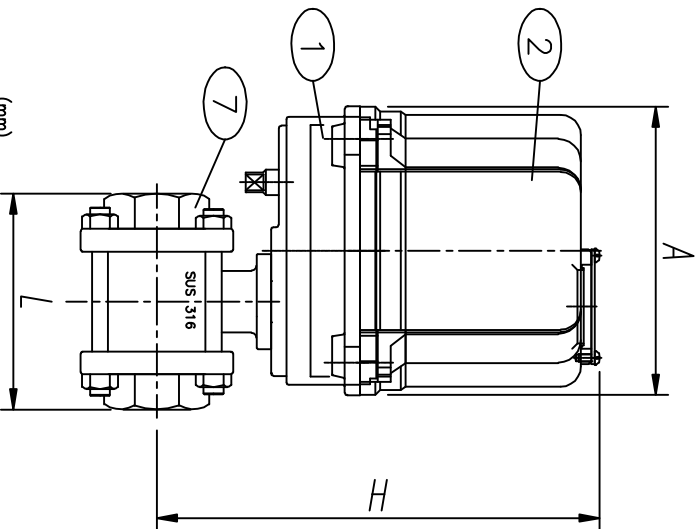
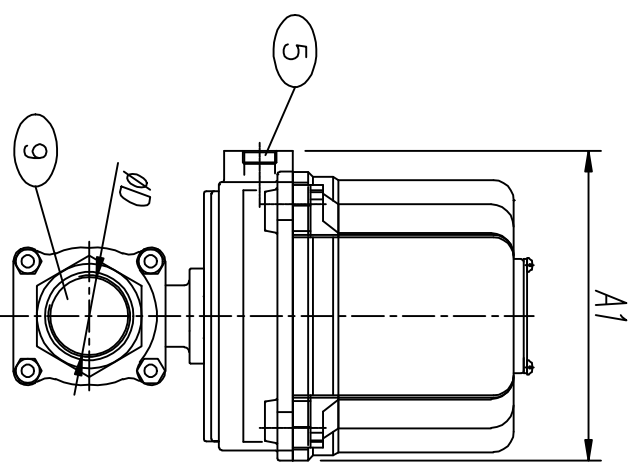
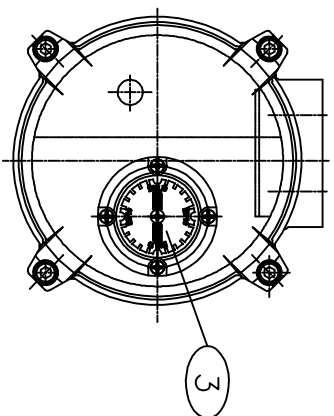

NO.	PART NAME	QTY	MATERIAL	REMARK
1	BODY	1	A10C12	
2	TOP COVER	1	A10C12	
3	WINDOW	1	PC	
4	HANDLE	2	SCM440	
5	CONDUIT ENTRIES	2		
6	DRIVE BUSHING	1	SMF-5030	
7	BODY	1	SUS316	
8	BALL	1	SUS316	
9	STEM	1	PTFE	
10				
11				
12				
13				
14				
15				

TAG NO.

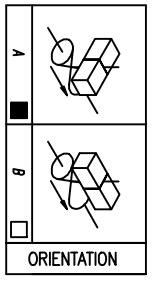
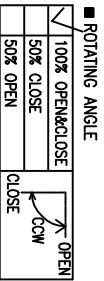

■ DIMANSSION (mm)

MODEL	QTY	MOTOR	H (APPROX.)	H	L±1.6	END CONNECTION	
KTQ0080-50S3	-	160	121	211	40	130	50
KTQ0080-40S3	-	160	121	208	40	110	40
KTQ0040-32S3	-	113.5	121.8	202	-	100	32
KTQ0040-25S3	-	113.5	121.8	190	-	85	25
KTQ0020-20S3	-	φ89.4	109.7	129	50	75	20
KTQ0020-15S3	-	φ89.4	109.7	125	50	65	15
KTQ0020-10S3	-	φ89.4	109.7	120	50	60	10
KTQ0020-8S3	-	φ89.4	109.7	116	50	60	8

■ INSTALLATION SCHEMATIC

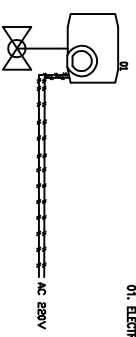

01. ELECTRIC ACTUATOR

Rev.	Date	Description	Pre'd	Ch'e'd	App'd

Designed by: _____
 Checked by: _____
 Approved by: _____

Model: KTQ0020-8S3 ~ KTQ0080-50S3

Drawing no. A110214-01-02

Size: A4

Scale: N:S

Unit: mm

